

- NOTES: FINISH (PLATING THICKNESS MICRO-INCHES)
1. BRASS PER JIS H3250 C3604BD.
 2. PTFE: ASTM-D-1475.
 3. SILICONE RUBBER: ASTM-E-1418PSI.
 4. NICKEL PL. 100 MIN. OVER COPPER PL. 50 MIN.
 5. GOLD PL. 3 MIN. OVER NICKEL PL. 50 MIN. OVER COPPER PL. 50 MIN.

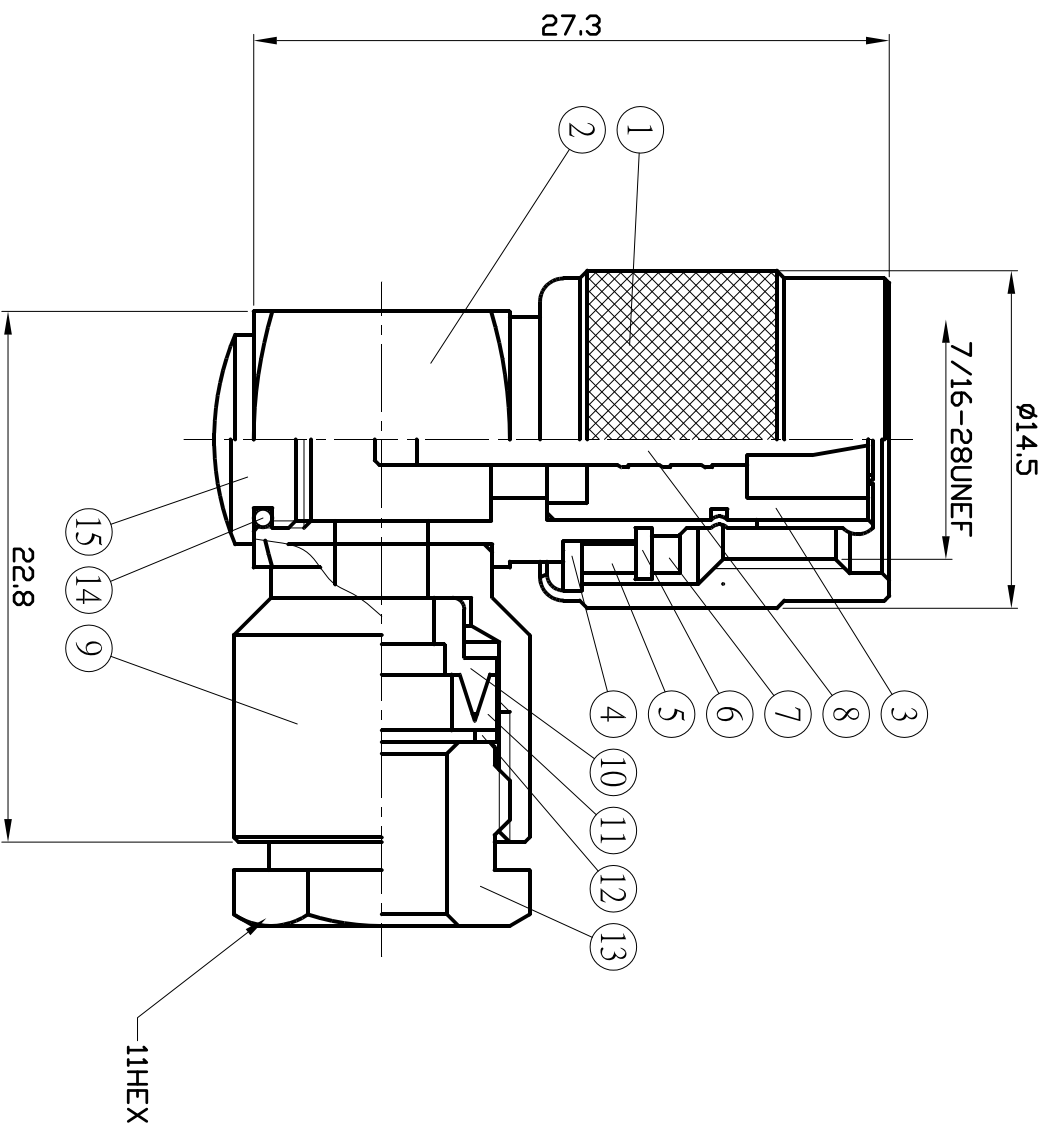

15	GAP	NOTE 1	NOTE 4	1	BNCI8-58L-15
14	GAP GASKET	NOTE 3		1	BNCI8-58L-14
13	HEX NUT	NOTE 1	NOTE 4	1	BNCI8-59-13
12	WASHER	NOTE 1	NOTE 4	1	BNCI8-58-12
11	GASKET	NOTE 3		1	BNCI8-58-11
10	BRAID CLAMP	NOTE 1	NOTE 4	1	BNCI8-59-10
9	CLAMP BODY	NOTE 1	NOTE 4	1	BNCI8-58L-9
8	CENTER PIN	NOTE 1	NOTE 5	1	BNCI8-58L-8
7	GASKET	NOTE 3		1	BNCI1-7
6	WASHER	NOTE 1	NOTE 4	1	BNCI1-6
5	RING	SK 5	NOTE 4	1	TNCI1-5
4	WASHER	NOTE 1	NOTE 4	1	BNCI1-4
3	INSULATOR	NOTE 2		1	BNCI1-58-3
2	BODY	NOTE 1	NOTE 4	1	BNCI8-58L-2
1	SHELL	NOTE 1	NOTE 4	1	TNCI1-SHELL
NO.	DESCRIPTION	MATERIAL	FINISH	QTY	PART NO.

DIMENSION ARE MILLIMETERS
UNLESS OTHERWISE SPECIFIED
TOLERANCES

1-10 = ±0.2
10-30 = ±0.4
30-200 = ±1.5
200-1000 = ±10
1000-~ = ±25

SCALE

3 / 1

REV

-

UNIT

M/M

TITLE

TNC PLUG RIGHT ANGLE
CRIMP CABLE LMR300

DRAWING NO.

TNCI8-L300L

CHECKED

科曼實業有限公司
Interconn enterprise

DRAWN

06/25/2013

DATE

06/25/2013

DATE